



# AI-SAW TECHNOLOGY CO., LTD.

No. 3, Industrial 2nd Rd., Ping-Chen Industrial District,  
Taoyuan, 324, Taiwan, R.O.C.

TEL: 886-3-4690038 FAX: 886-3-4697532

E-mail: [tstsales@mail.taisaw.com](mailto:tstsales@mail.taisaw.com) Web: [www.taisaw.com](http://www.taisaw.com)

## Product Specifications Approval Sheet

Product Description: GPS, GLONASS, Beidou and Galileo Front-End Module 2.5x2.5 mm

TST Part No.: TN0081A (This part is compliant with AEC-Q100)

Customer Part No.: \_\_\_\_\_

Customer signature required
Company: _____
Division: _____
Approved by : _____
Date: _____

Checked by: \_\_\_\_\_ Hayley Chou *Hayley Chou*

Approved by: \_\_\_\_\_ Andy Yu *Andy Yu*

Date: \_\_\_\_\_ 2020/09/30

1. Customer signed back is required before TST can proceed with sample build and receive orders.
2. Orders received without customer signed back will be regarded as agreement on the specifications.
3. Any specifications changes must be approved upon by both parties and a new revision of specifications shall be released to reflect the changes.



# TAI-SAW TECHNOLOGY CO., LTD.

No. 3, Industrial 2nd Rd., Ping-Chen Industrial District,  
Taoyuan, 324, Taiwan, R.O.C.  
TEL: 886-3-4690038 FAX: 886-3-4697532

E-mail: [ttsales@mail.taisaw.com](mailto:ttsales@mail.taisaw.com) Web: [www.taisaw.com](http://www.taisaw.com)

GPS, GLONASS, BeiDou and Galileo Front-End Module 2.5x2.5 mm

MODEL NO.: TN0081A

REV. NO.:8.0

## A. GENERAL DESCRIPTION:

1. The TN0081A is a front-end module (FEM) designed for GPS, GLONASS, BeiDou and Galileo applications.
2. The TN0081A offers high gain, low noise figure, high linearity and very high out-band rejection characteristics brought by Electrostatic Sensitive Device (ESD) included high performance pre- SAW filter, low noise amplifier (LNA) and post- SAW filter.
3. The TN0081A offers only two external components and very small HFFP10-CD package that is 2.5x2.5 mm.

RoHS Compliant

Lead-free soldering

## B. ABSOLUTE MAXIMUM RATINGS:

1. Supply voltage:  $V_{DD}=5\text{ V}$
2. Control voltage:  $V_{CTL}=5\text{ V}$
3. Input power:
  - $P_{IN}$  (inband): +15 dBm( $V_{DD}=2.8\text{ V}$ ,  $f=1575, 1597\sim 1606\text{ MHz}$ )
  - $P_{IN}$  (outband): +27 dBm( $V_{DD}=2.8\text{ V}$ ,  $f=50\sim 1460, 1710\sim 4000\text{ MHz}$ )
4. Power dissipation:  $P_D=580\text{ mW}$ (4-layer FR4 PCB with through-hole(101.5x114.5 mm),  $T_j=110\text{ }^\circ\text{C}$ )
5. Terminating source impedance:  $Z_s = 50$  (Single-ended)  
Terminating load impedance:  $Z_L = 50$  (Single-ended)
6. Operating temperature range:  $-40\text{ }^\circ\text{C}$  to  $+105\text{ }^\circ\text{C}$
7. Storage temperature range:  $-40\text{ }^\circ\text{C}$  to  $+110\text{ }^\circ\text{C}$

## C. FEATURES:

1. Available for GPS, GLONASS, BeiDou and Galileo
2. Low supply voltage: 1.8/ 2.8 V typ.
3. Low current consumption:
  - 2.6/3.3mA typ.(at  $V_{DD}=1.8/ 2.8\text{ V}$ ,  $V_{CTL}=1.8\text{ V}$ )
  - 0.1 $\mu\text{A}$  typ.(at  $V_{DD}=1.8/ 2.8\text{ V}$ ,  $V_{CTL}=0\text{ V}$  (Stand-by mode))
4. High gain: 17.5/18.5 dB typ. (at  $V_{DD}=1.8/2.8\text{ V}$ ,  $V_{CTL}=1.8\text{ V}$ ,  $f=1575\text{ MHz}$ , 1597~1606 MHz, 1559~1591 MHz)
5. Low noise figure:
  - 1.65/1.60 dB typ.(at  $V_{DD}=1.8/ 2.8\text{ V}$ ,  $V_{CTL}=1.8\text{ V}$ ,  $f=1575\text{ MHz}$ )
  - 1.75/1.70 dB typ.(at  $V_{DD}=1.8/ 2.8\text{ V}$ ,  $V_{CTL}=1.8\text{ V}$ ,  $f=1597\sim 1606\text{ MHz}$ , 1559~1591 MHz)

6. High out band rejection(at  $V_{DD}=1.8/2.8$  V,  $V_{CTL}=1.8$  V):
- 85 dBc typ. (  $f=704\sim 915$  MHz, relative to 1575 MHz)
  - 75 dBc typ. (  $f=1710\sim 1980$  MHz, relative to 1575 MHz)
7. Small package size: HFFP10-CD: 2.5 mmx2.5 mm (typ.),  $t=0.63$  mm (max.)
8. Moisture Sensitivity Level: Level 1

#### D. ELECTRICAL CHARACTERISTICS 1 (DC):

(General conditions:  $T_a=+25$  °C)

Parameters Description		Symbol	Unit	Min.	Typ.	Max.
Supply Voltage		$V_{DD}$	V	1.5	-	3.3
Control Voltage (High)		$V_{CTL(H)}$	V	1.5	1.8	3.3
Control Voltage (Low)		$V_{CTL(L)}$	V	0	0	0.3
Supply Current 1	RF OFF, $V_{DD}=2.8$ V, $V_{CTL}=1.8$ V	$I_{DD1}$	mA	-	3.3	6.4
Supply Current 2	RF OFF, $V_{DD}=1.8$ V, $V_{CTL}=1.8$ V	$I_{DD2}$	mA	-	2.6	5.9
Supply Current 3	RF OFF, $V_{DD}=2.8$ V, $V_{CTL}=0$ V	$I_{DD3}$	$\mu$ A	-	0.1	5.0
Supply Current 4	RF OFF, $V_{DD}=1.8$ V, $V_{CTL}=0$ V	$I_{DD4}$	$\mu$ A	-	0.1	5.0
Control Current	$V_{CTL}=1.8$ V	$I_{CTL}$	$\mu$ A	-	5.0	15.0

#### E. ELECTRICAL CHARACTERISTICS 2 (RF):

(General conditions:  $V_{DD}=2.8$  V,  $V_{CTL}=1.8$  V,  $f_{RF}=1575$  MHz, 1597~1606 MHz, 1559~1591 MHz  $T_a=+25$  °C,  $Z_s=Z_l=50$  ohm, with application circuit)

Parameters Description		Symbol	Unit	Min.	Typ.	Max.
Small Signal Gain (GPS)1	$f=1575$ MHz (GPS) Exclude PCB, Connector Losses(0.19 dB)	GainGPS1	dB	17.0	18.5	-
Small Signal Gain (GLONASS)1	$f=1597\sim 1606$ MHz(GLONASS) Exclude PCB, Connector Losses(0.19 dB)	GainGLN1	dB	17.0	18.5	-
Small Signal Gain (BeiDou, Galileo)1	$f=1559\sim 1591$ MHz(BeiDou, Galileo) Exclude PCB, Connector Losses(0.19 dB)	GainBG1	dB	17.0	18.5	-
Noise Figure (GPS)1	$f=1575$ MHz (GPS) Exclude PCB, Connector Losses(0.09 dB)	NFGPS1	dB	-	1.6	2.1
Noise Figure (GLONASS)1	$f=1597\sim 1606$ MHz (GLONASS) Exclude PCB, Connector Losses(0.09 dB)	NFGLN1	dB	-	1.7	2.2
Noise Figure (BeiDou, Galileo)1	$f=1559\sim 1591$ MHz(BeiDou, Galileo) Exclude PCB, Connector Losses(0.09 dB)	NFBG1	dB	-	1.7	2.2

Input Power at 1dB Gain Compression Point 1	f=1575, 1597~1606 MHz, 1559~1591 MHz	P-1dB(IN)1	dBm	-	-15.0	-
Input 3rd Order Intercept Point 1	f1=1575 MHz, f2=f1+/- 1 MHz, Pin=-30 dBm	IIP3_1	dBm	-	-3.0	-
Out of Band Input 2nd Order Intercept Point 1	f1=824.6 MHz at +15 dBm, f2=2400 MHz at +15 dBm, fmeas=1575.4 MHz	IIP2_OB1	dBm	-	+72	-
Out of Band Input 3rd Order Intercept Point 1	f1=1712.7 MHz at +15 dBm, f2=1850 MHz at +15 dBm, fmeas=1575.4 MHz	IIP3_OB1	dBm	-	+50	-
700MHz Harmonic1	Input jammer tone: 787.76 MHz at +15 dBm Measure the harmonic tone at 1575.52 MHz	2fo1	dBm	-	-30	-
Out-of-Band Input Power 1dB Compression 1	fjam=900 MHz, fmeas=1575 MHz at Pin=-40 dBm	P-1dB(IN)_OB1-1	dBm	-	+24	-
	fjam=1710 MHz, fmeas=1575 MHz at Pin=-40 dBm	P-1dB(IN)_OB1-2	dBm	-	+24	-
Low Band Rejection 1	f=704~915 MHz, relative to 1575 MHz	BR_L1	dBc	-	85	-
High Band Rejection 1	f=1710~1980MHz, relative to 1575MHz	BR_H1	dBc	-	75	-
WLAN Band Rejection 1	f=2400~2500 MHz, relative to 1575 MHz	BR_W1	dBc	-	72	-
RF IN Return Loss(GPS)1	f=1575 MHz (GPS)	RLiGPS1	dB	-	7.5	-
RF IN Return Loss(GLONASS)1	f=1597~1606 MHz(GLONASS)	RLiGLN1	dB	-	7.5	-
RF IN Return Loss(BeiDou, Galileo)1	f=1559~1591 MHz(BeiDou, Galileo)	RLiBG1	dB	-	4.2	-
RF OUT Return Loss(GPS)1	f=1575 MHz(GPS)	RLoGPS1	dB	-	11	-
RF OUT Return Loss(GLONASS)1	f=1597~1606 MHz(GLONASS)	RLoGLN1	dB	-	15	-
RF OUT Return Loss(BeiDou, Galileo)1	f=1559~1591 MHz(BeiDou, Galileo)	RLoBG1	dB	-	7.4	-
Group Delay Time Deviation (GLONASS)1	f=1597~1606 MHz(GLONASS)	GDTGLN1	ns	-	8.0	-
Group Delay Time Deviation (BeiDou, Galileo)1	f=1559~1591 MHz(BeiDou, Galileo)	GDTBG1	ns	-	35	-

### F. ELECTRICAL CHARACTERISTICS 3 (RF):

(General conditions: V<sub>DD</sub>=1.8 V, V<sub>CTL</sub>=1.8 V, f<sub>RF</sub>=1575 MHz, 1597~1606 MHz, 1559~1591 MHz, T<sub>a</sub>=+25 °C, Z<sub>s</sub>=Z<sub>l</sub>=50 ohm, with application circuit)

Parameters Description		Symbol	Unit	Min.	Typ.	Max.
Small Signal Gain (GPS)2	f=1575 MHz (GPS) Exclude PCB, Connector Losses	GainGPS2	dB	15.5	17.5	-

Small Signal Gain (GLONASS)2	f=1597~1606 MHz (GLONASS) Exclude PCB, Connector Losses	GainGLN2	dB	15.5	17.5	-
Small Signal Gain (BeiDou, Galileo)2	f=1559~1591 MHz (BeiDou, Galileo) Exclude PCB, Connector Losses	GainBG2	dB	15.5	17.5	-
Noise Figure (GPS)2	f=1575 MHz (GPS) Exclude PCB, Connector Losses	NFGPS2	dB	-	1.65	2.20
Noise Figure (GLONASS)2	f=1597~1606 MHz (GLONASS) Exclude PCB, Connector Losses	NFGLN2	dB	-	1.75	2.35
Noise Figure (BeiDou, Galileo)2	f=1559~1591 MHz (BeiDou, Galileo) Exclude PCB, Connector Losses	NFBG2	dB	-	1.75	2.35
Input Power at 1dB Gain Compression Point 2	f=1575, 1597~1606 MHz, 1559~1591 MHz	P-1dB(IN)2	dBm	-	-17.0	-
Input 3rd Order Intercept Point 2	f1=1575 MHz, f2=f1 +/- 1 MHz, Pin=-30 dBm	IIP3_2	dBm	-	-6.0	-
Out of Band Input 2nd Order Intercept Point 1	f1=824.6 MHz at +15 dBm, f2=2400 MHz at +15 dBm, fmeas=1575.4 MHz	IIP2_OB2	dBm	-	+72	-
Out of Band Input 3rd Order Intercept Point 2	f1=1712.7 MHz at +15 dBm, f2=1850 MHz at +15 dBm, fmeas=1575.4 MHz	IIP3_OB2	dBm	-	+50	-
700 MHz Harmonic2	Input jammer tone: 787.76 MHz at +15 dBm Measure the harmonic tone at 1575.52 MHz	2fo2	dBm	-	-30	-
Out-of-Band Input Power 1 Db Compression 2	fjam=900 MHz, fmeas=1575 MHz at Pin=-40 dBm	P-1dB(IN)_ OB1-2	dBm	-	+24	-
	fjam=1710 MHz, fmeas=1575 MHz at Pin=-40 dBm	P-1dB(IN)_ OB2-2	dBm	-	+24	-
Low Band Rejection 2	f=704~915 MHz, relative to 1575 MHz	BR_L2	dBc	-	85	-
High Band Rejection 2	f=1710~1980 MHz, relative to 1575 MHz	BR_H2	dBc	-	75	-
WLAN Band Rejection 2	f=2400~2500 MHz, relative to 1575 MHz	BR_W2	dBc	-	72	-
RF IN Return Loss (GPS)2	f=1575 MHz (GPS)	RLiGPS2	dB	-	7.5	-
RF IN Return Loss (GLONASS)2	f=1597~1606 MHz (GLONASS)	RLiGLN2	dB	-	7.5	-
RF IN Return Loss (BeiDou, Galileo)2	f=1559~1591 MHz (BeiDou, Galileo)	RLiBG2	dB	-	4.1	-
RF OUT Return Loss(GPS)2	f=1575 MHz (GPS)	RLoGPS2	dB	-	10	-
RF OUT Return Loss(GLONASS)2	f=1597~1606 MHz (GLONASS)	RLoGLN2	dB	-	13	-
RF OUT Return Loss(BeiDou, Galileo)2	f=1559~1591 MHz (BeiDou, Galileo)	RLoBG2	dB	-	6.9	-
Group Delay Time Deviation (GLONASS) 2	f=1597~1606 MHz (GLONASS)	GDTGLN2	ns	-	8.0	-
Group Delay Time Deviation (BeiDou, Galileo) 2	f=1559~1591 MHz (BeiDou, Galileo)	GDTBG2	ns	-	36	-

## G. FREQUENCY CHARACTERISTICS 1:

(Conditions:  $V_{DD}=2.8$  V,  $V_{CTL}=1.8$  V,  $T_a=25$  °C,  $Z_s=Z_l=50$  ohm, with application circuit.)

Transfer function:

### S21 response (span: 250 MHz)

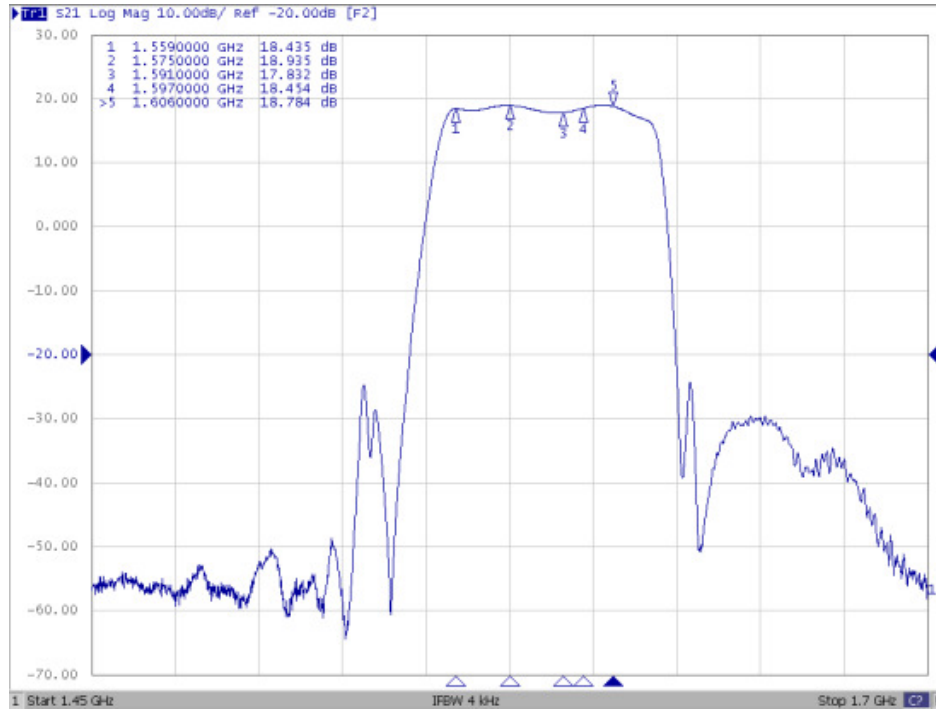

### S21 response

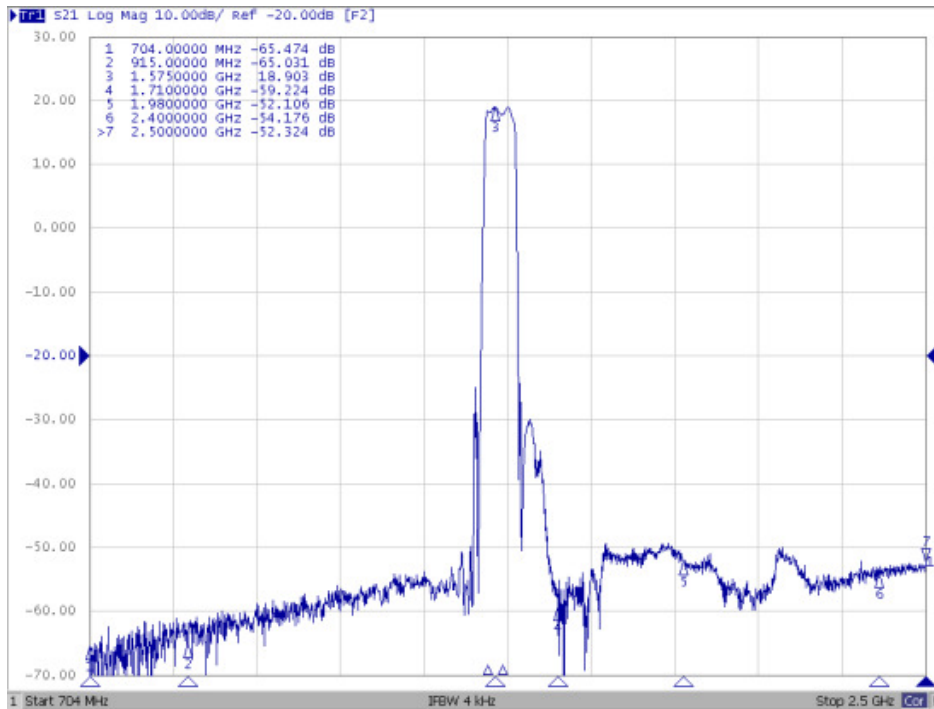

## Group Delay

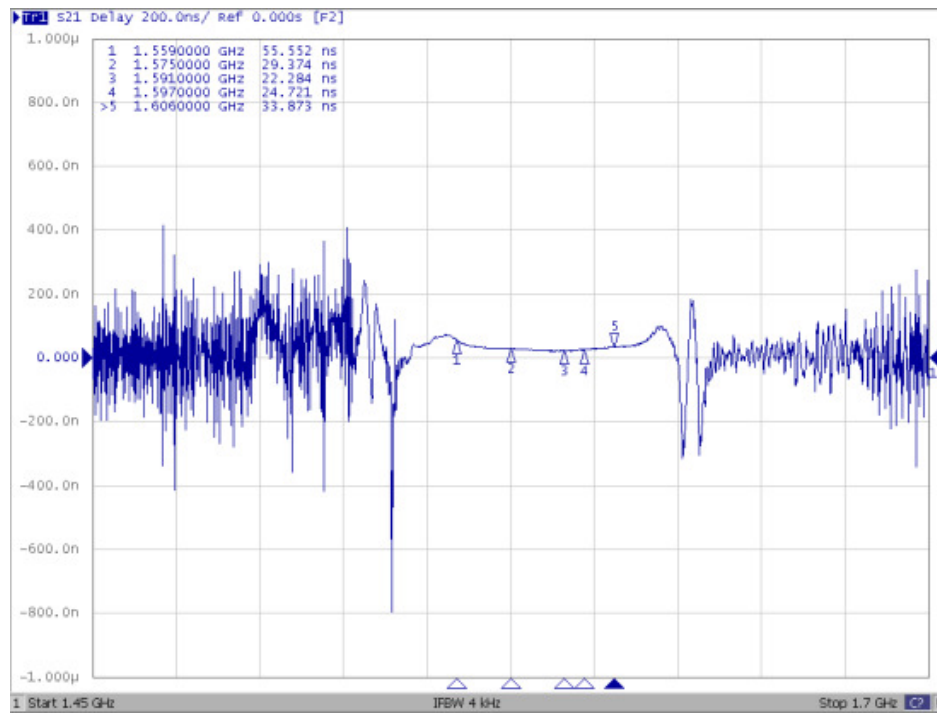

## Reflection functions:

### S11 VSWR

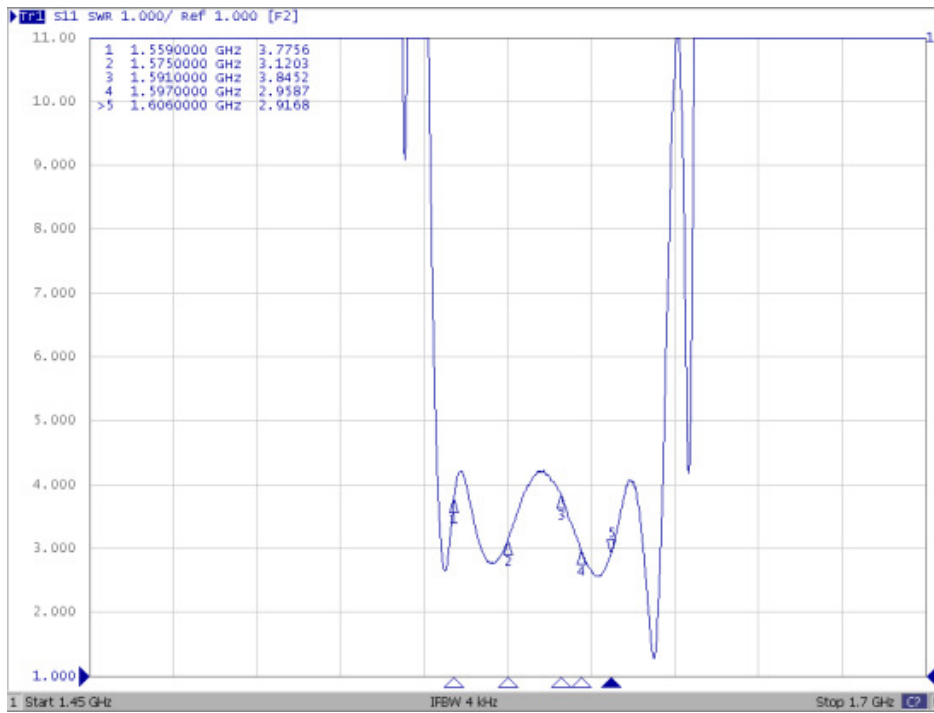

### S22 VSWR

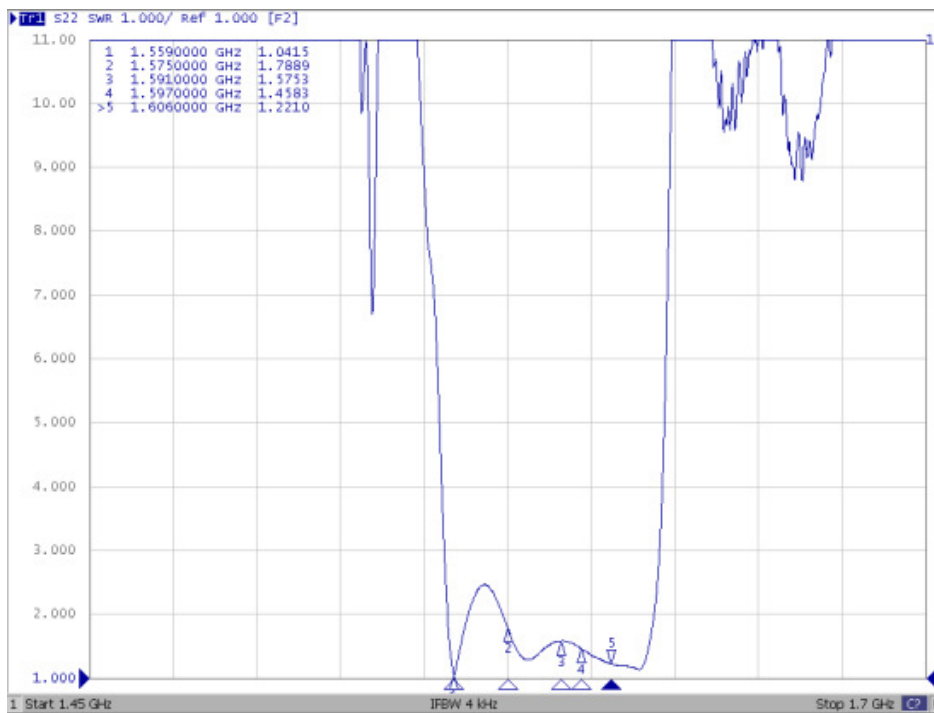

## S11 Smith Chart

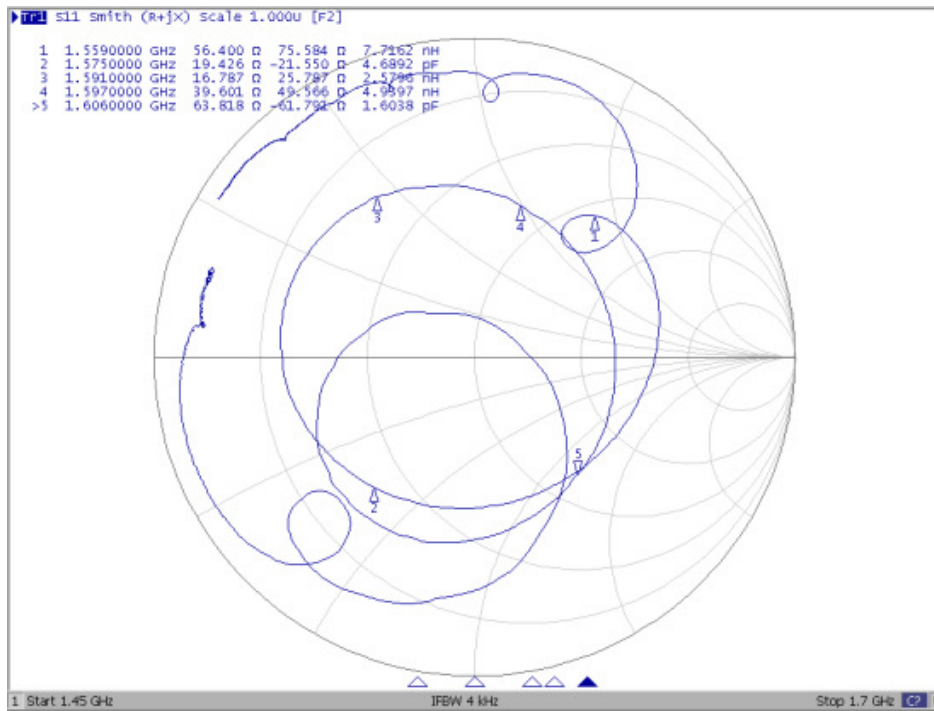

## S22 Smith Chart

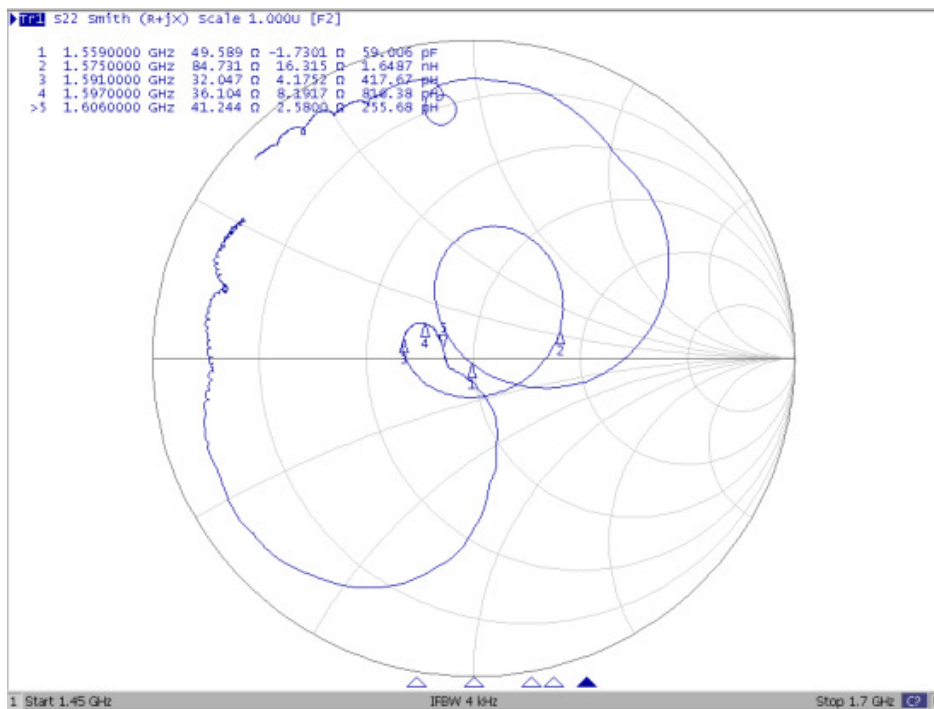

## S11 Return Loss

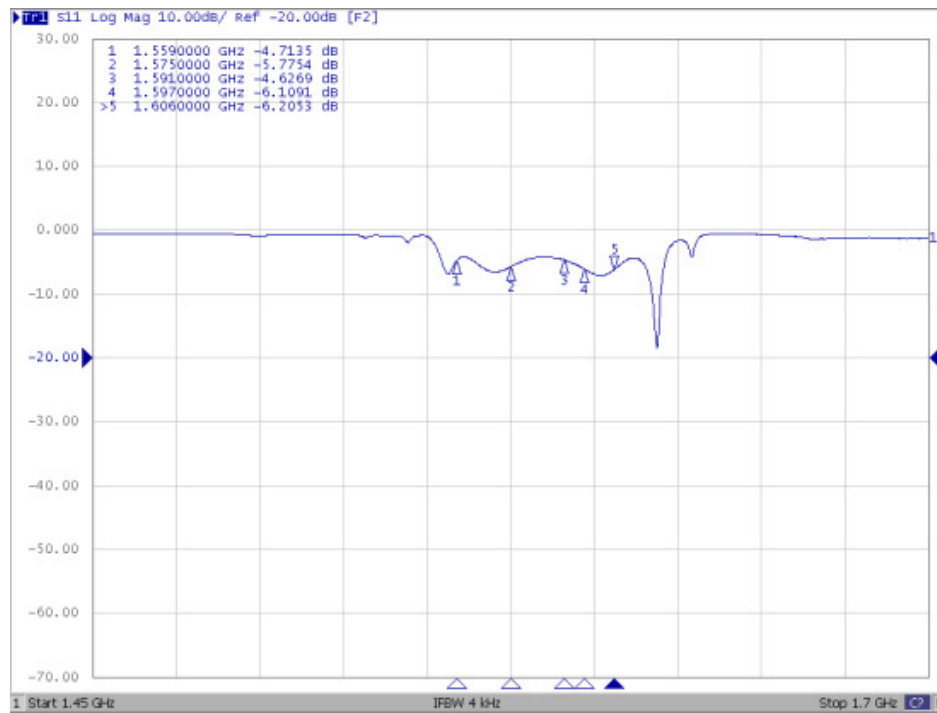

## S22 Return Loss

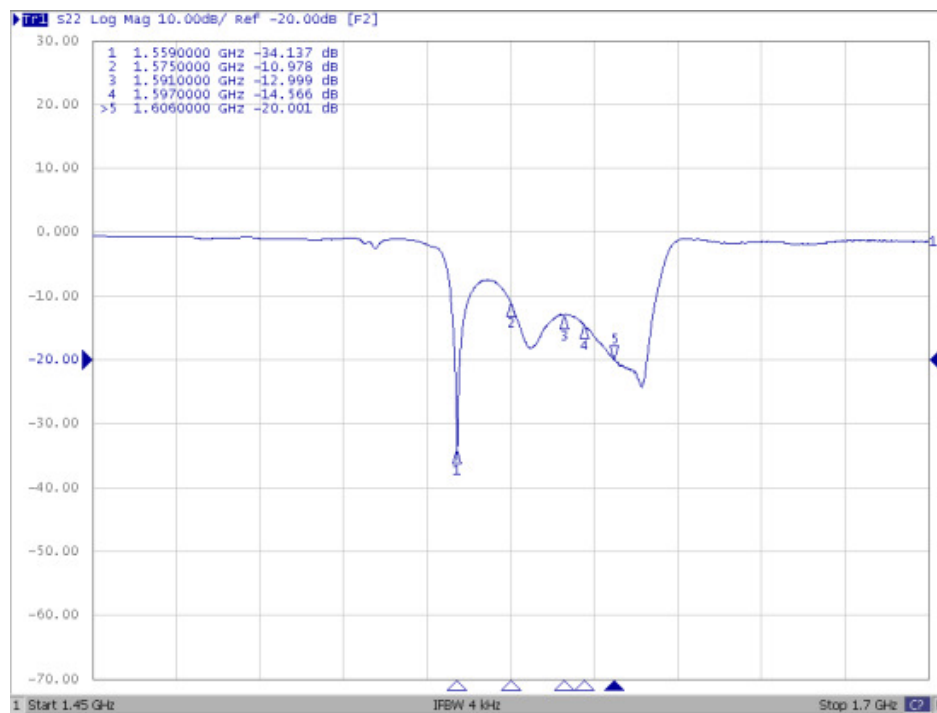

## H. FREQUENCY CHARACTERISTICS 2:

(Conditions:  $V_{DD}=1.8$  V,  $V_{CTL}=1.8$  V,  $T_a=25$  °C,  $Z_s=Z_l=50$  ohm, with application circuit.)

Transfer function:

### S21 response (span: 250 MHz)

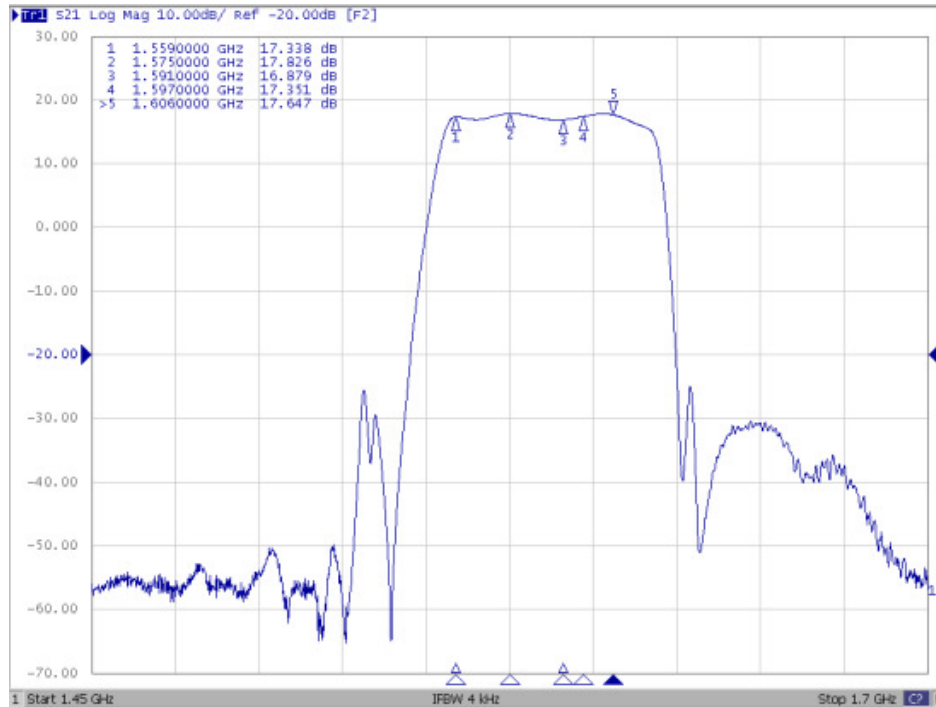

### S21 response

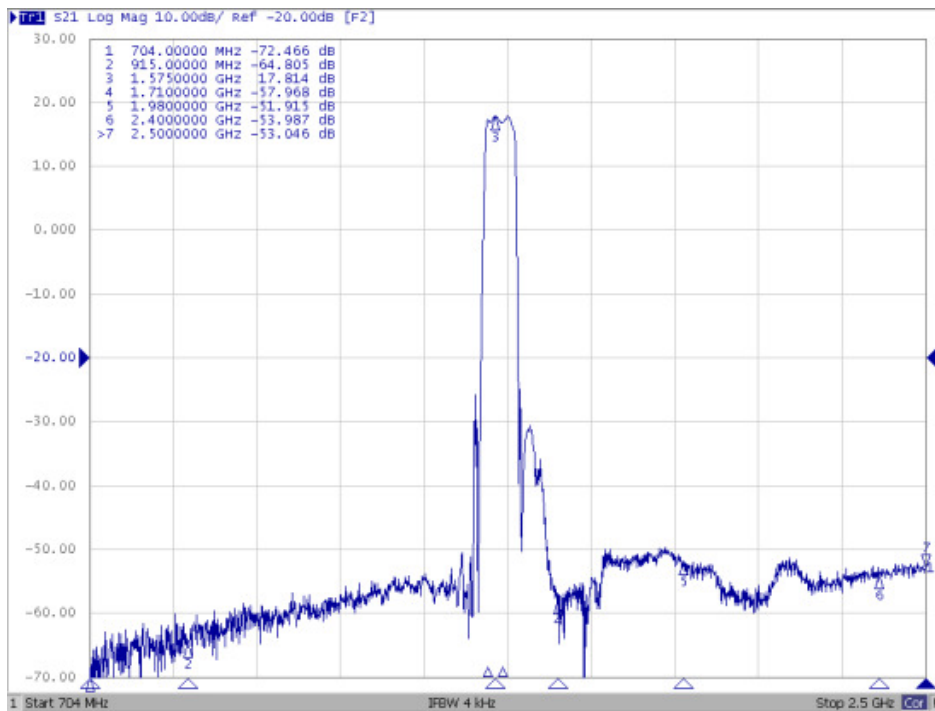

# Group Delay

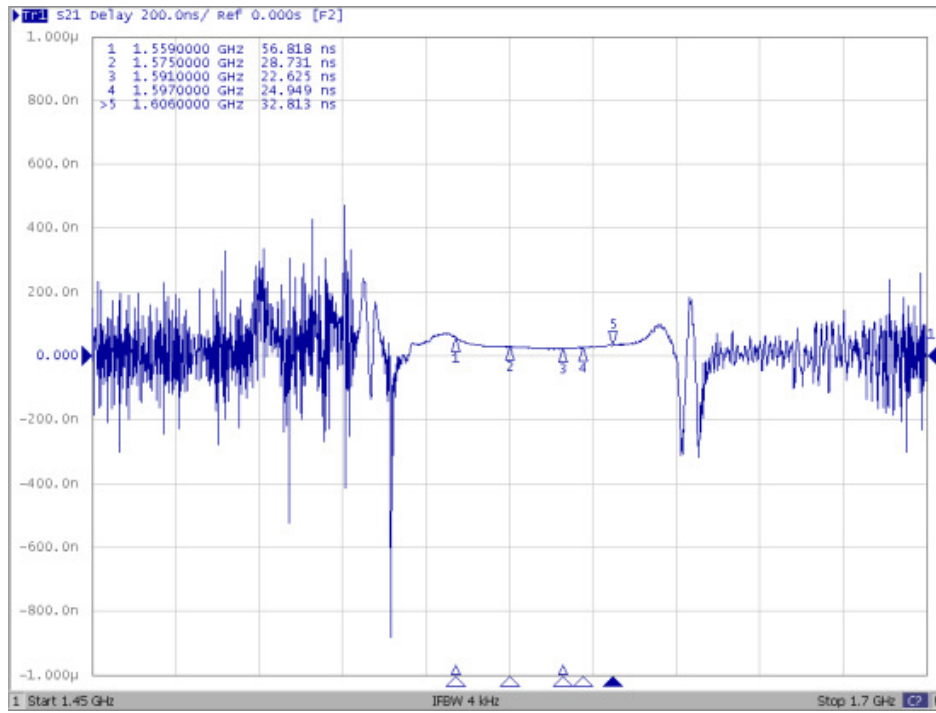

## Reflection functions:

### S11 VSWR

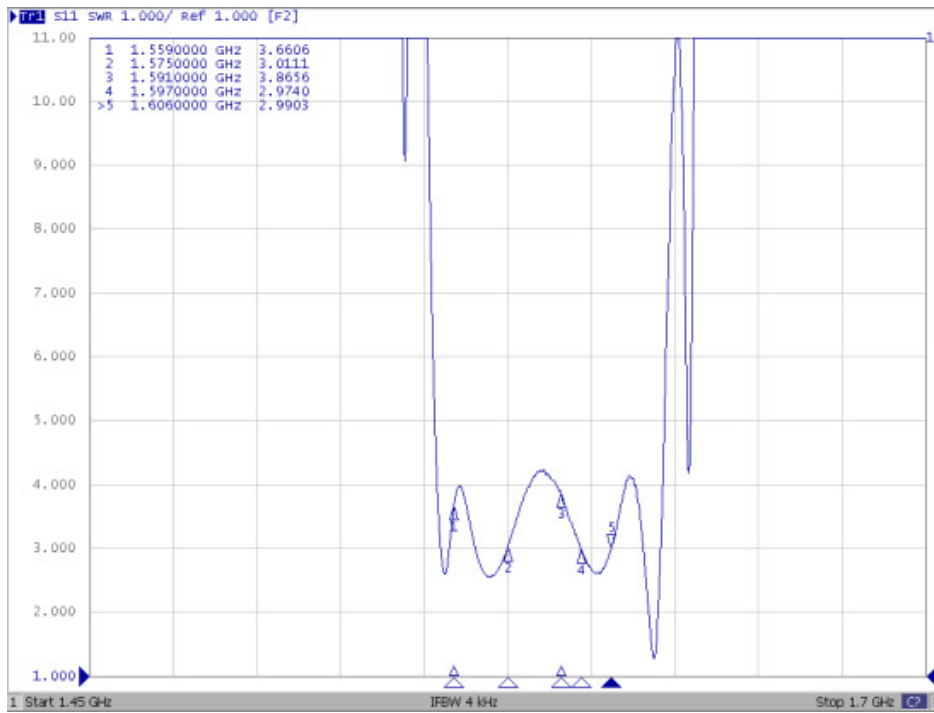

### S22 VSWR

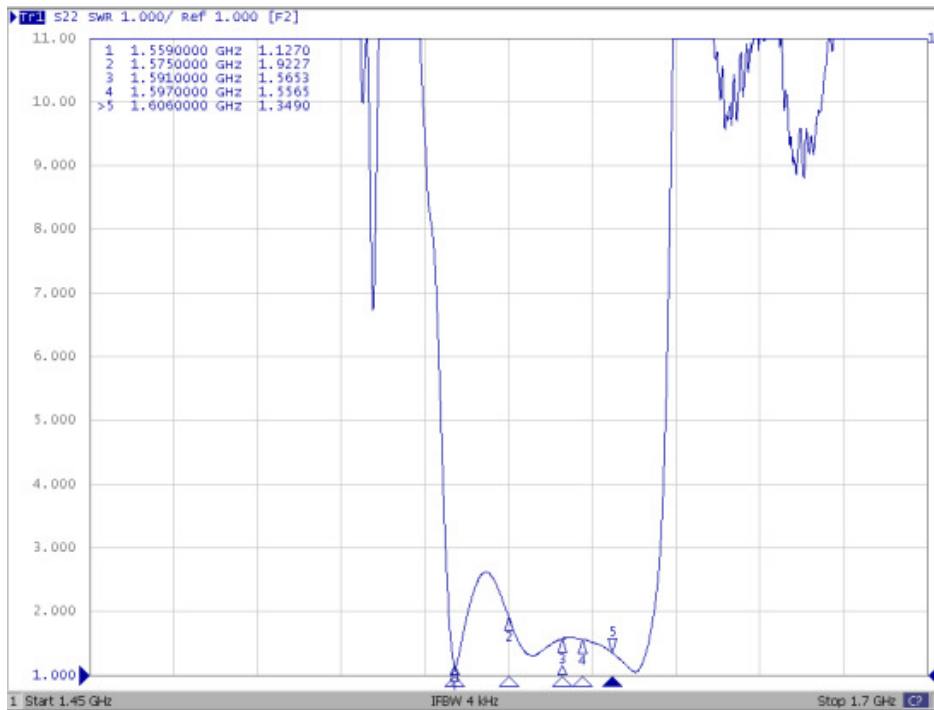

## S11 Smith Chart

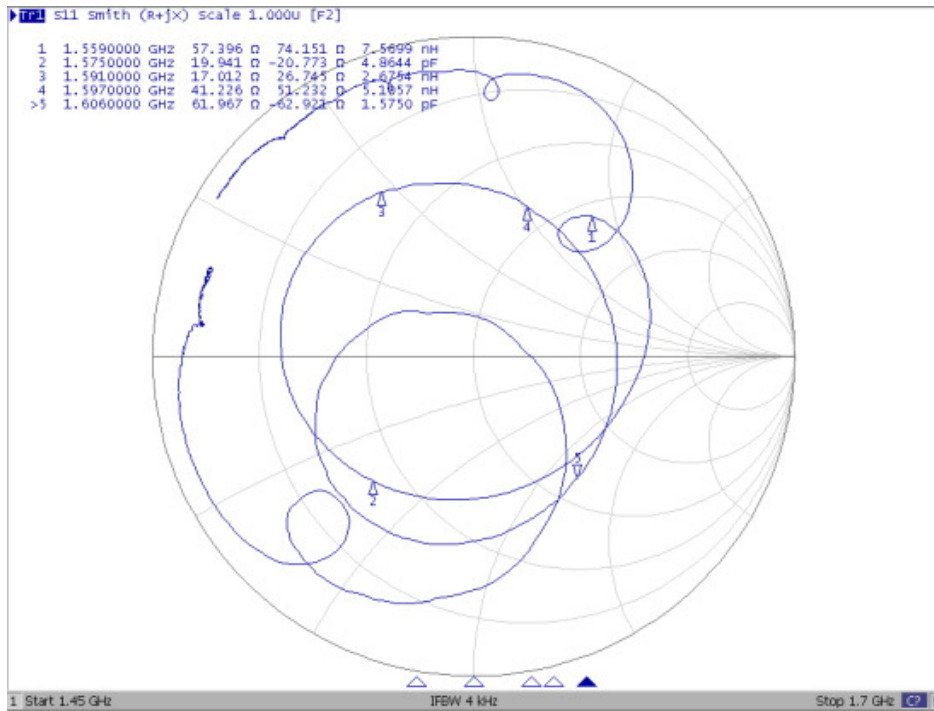

## S22 Smith Chart

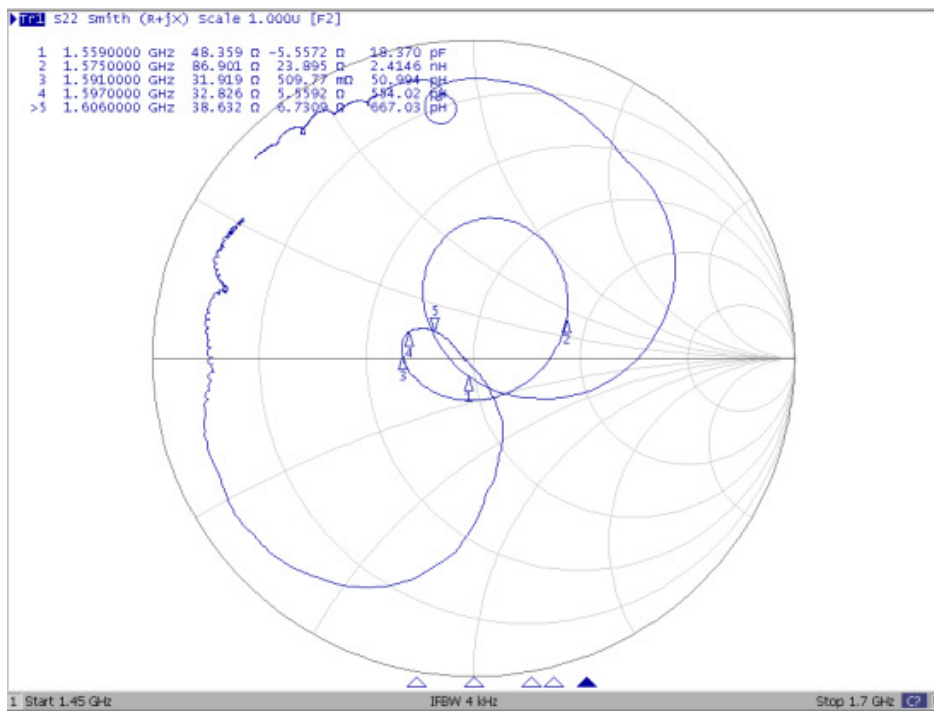

## S11 Return Loss

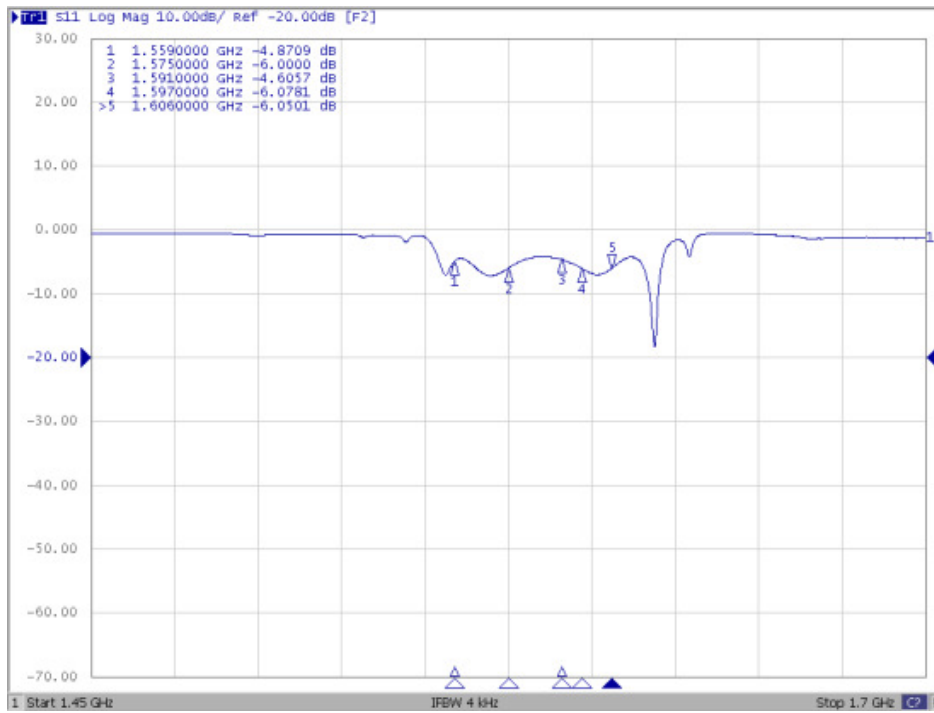

## S22 Return Loss

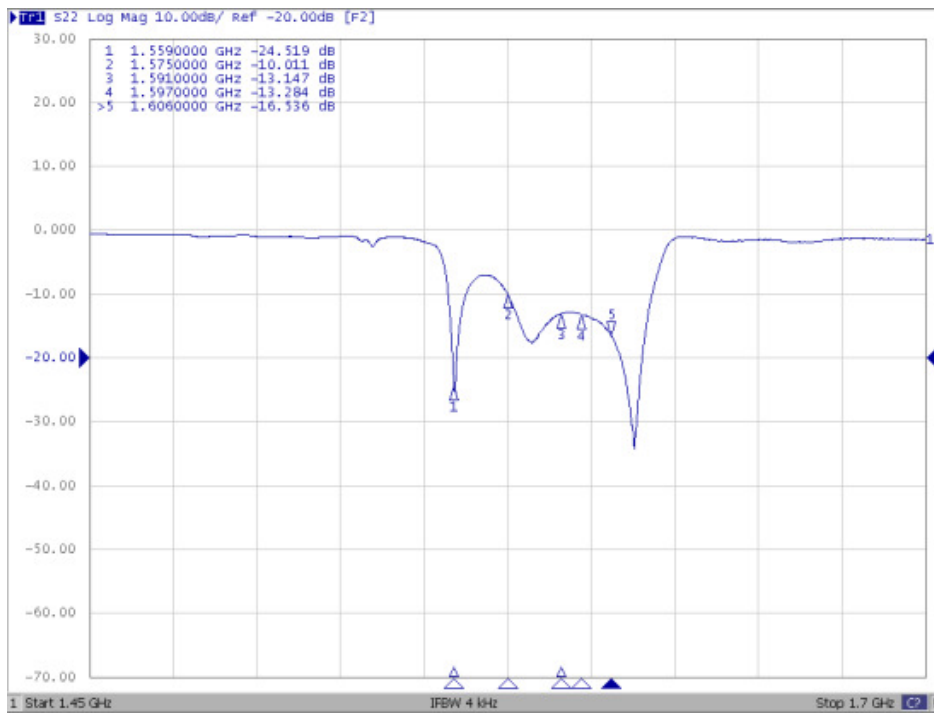

**I. MEASUREMENT CIRCUIT:**

Top View

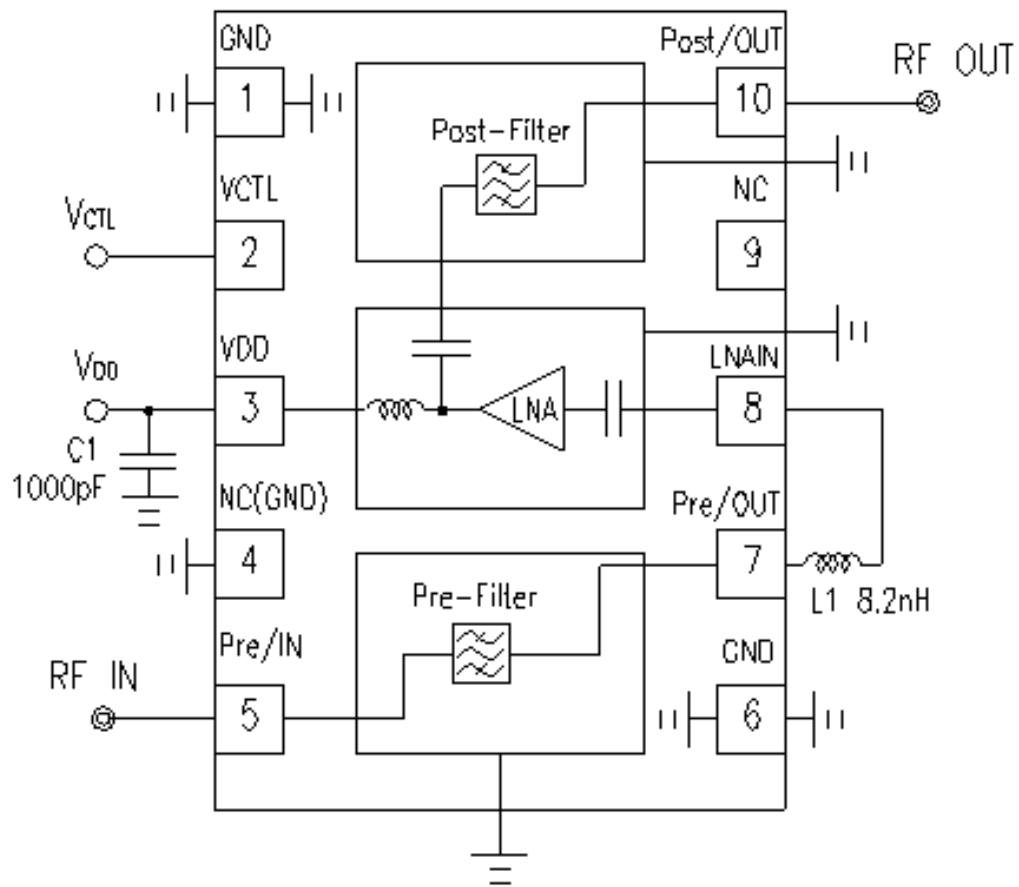

Parts list

Parts ID	Manufacture
L1	LQW15A Series (MURATA)
C1	GRM03 Series (MURATA)

**J. PACKAGE OUTLINE:**

TOP VIEW

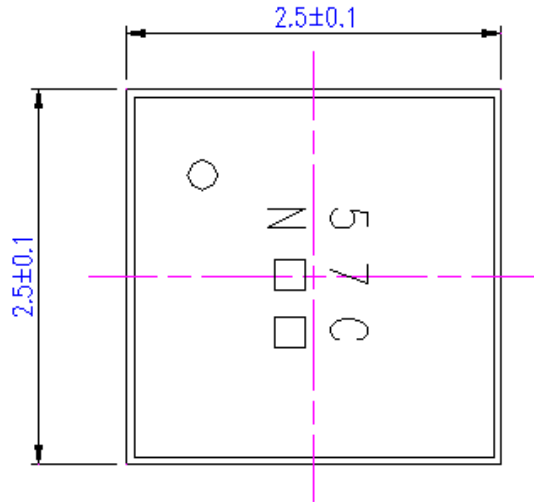

1. N: Manufacture year & month
2. □: Lot NO.
3. ○: pin index

**Unit: mm**

SIDE VIEW

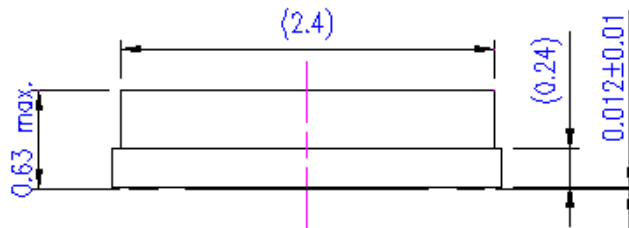

BOTTOM VIEW

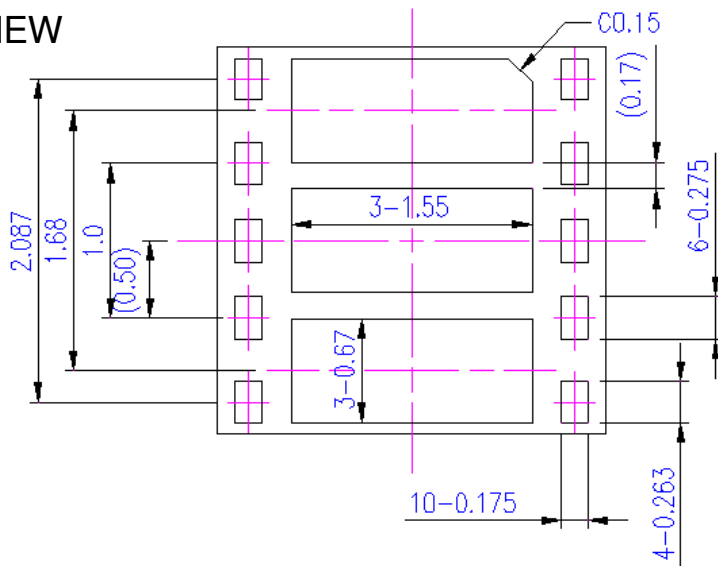

Exposed PAD  
Ground connection is required.

Manufacture year & month marking rule

Year	January	February	March	April	May	June	July	August	September	October	November	December
2020	n	p	q	r	s	t	u	v	w	x	y	z
2021	A	B	C	D	E	F	G	H	J	K	L	M
2022	N	P	Q	R	S	T	U	V	W	X	Y	Z
2023	a	b	c	d	e	f	g	h	j	k	l	m

(NOTE) Repetition evry four years

## K. PIN CONFIGURATION:

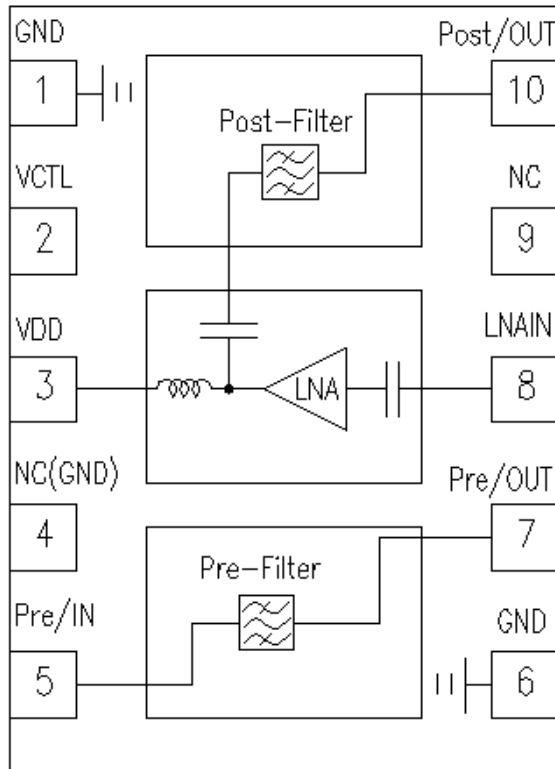

Top View

### TRUTH TABLE

“H”=V<sub>CTL</sub>(H), “L”=V<sub>CTL</sub>(L)

VCTL	Mode
H	Active mode
L	Stand-by mode

No.	SYMBOL	DESCRIPTION
1	GND	Ground terminal. This terminal should be connected to the ground plane as close as possible for excellent RF performance.
2	VCTL	Control voltage terminal.
3	VDD	Supply voltage terminal. Please connect bypass capacitor C1 with ground as close as possible.
4	NC(GND)	Ground terminal. Please connect this terminal with ground plane as close as possible for excellent RF performance.
5	PreIN	RF input terminal. This terminal connects to input of pre-SAW filter.
6	GND	Ground terminal. This terminal should be connected to the ground plane as close as possible for excellent RF performance.
7	PreOUT	Pre-SAW filter output terminal. This terminal connects to LNAIN with L1.
8	LNAIN	RF input terminal. This terminal requires only a matching inductor L1, and does not require DC blocking capacitor because of integrated capacitor.
9	NC(GND)	Ground terminal. This terminal should be connected to the ground plane as close as possible for excellent RF performance.
10	PostOUT	RF output terminal. This terminal requires no DC blocking capacitor since this terminal has integrated SAW that also works as DC blocking capacitor in nature.
Exposed Pad	GND	Ground terminal.

**L. EVALUATION BOARD:**

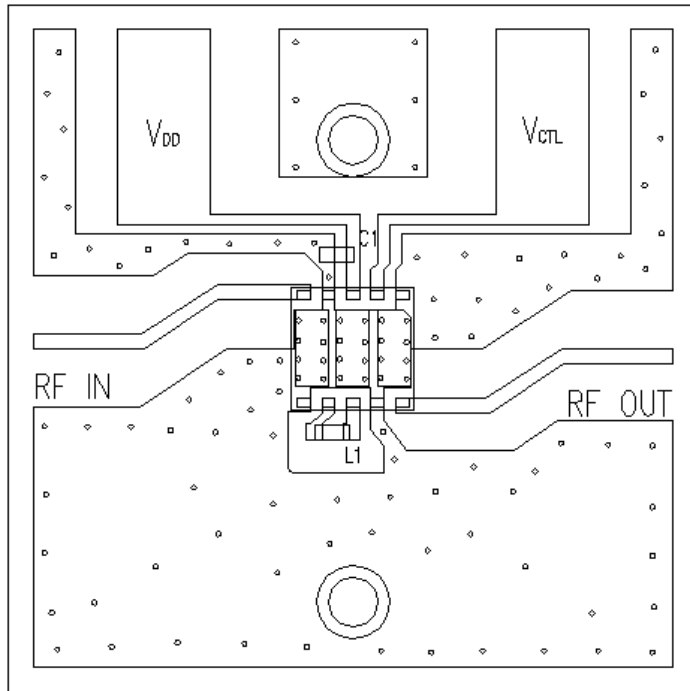

PCB  
 Substrate: FR-4  
 Thickness: 0.2 mm  
 Microstrip line width: 0.4 mm( $Z_0=50 \Omega$ )  
 Size: 14.0 mm x 14.0 mm

TOP VIEW

**<PCB LAYOUT GUIDELINE>**

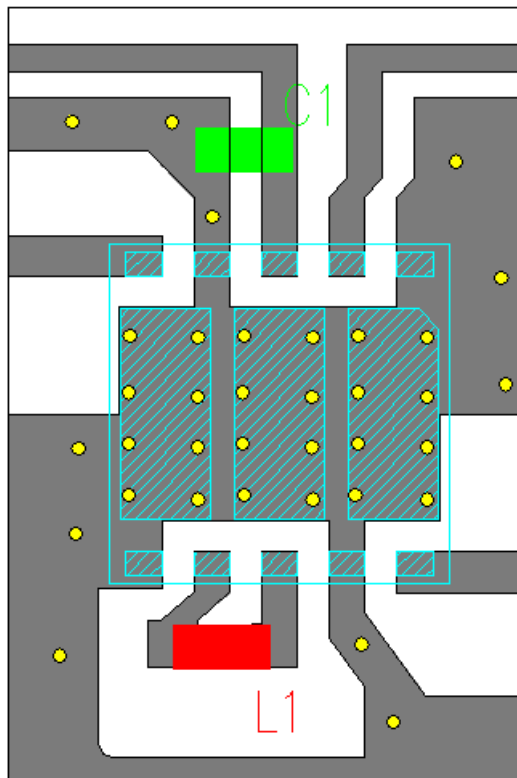

-  PCB
-  PKG Terminal
-  PCB Outline
-  GND Via Hole

**PRECAUTIONS**

- Please layout ground pattern under this FEM in order not to couple with RFIN and RFOUT terminal.
- All external parts should be placed as close as possible to the FEM.
- For good RF performance, all GND terminals must be connected to PCB ground plane of substrate, and via-holes for GND should be placed near the FEM.

**M. RECOMMENDED FOOTPRINT PATTERN:**

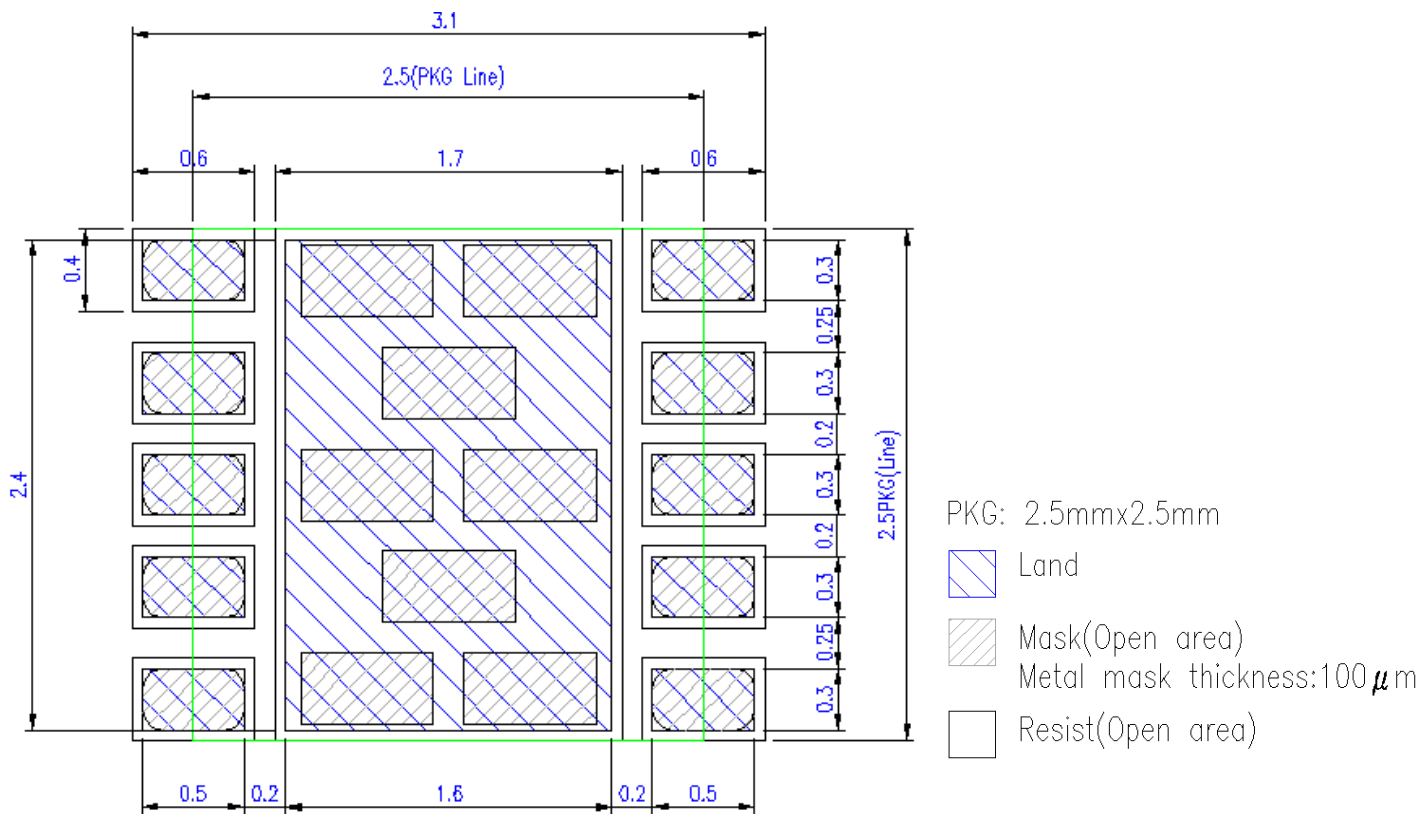

**Metal MASK**

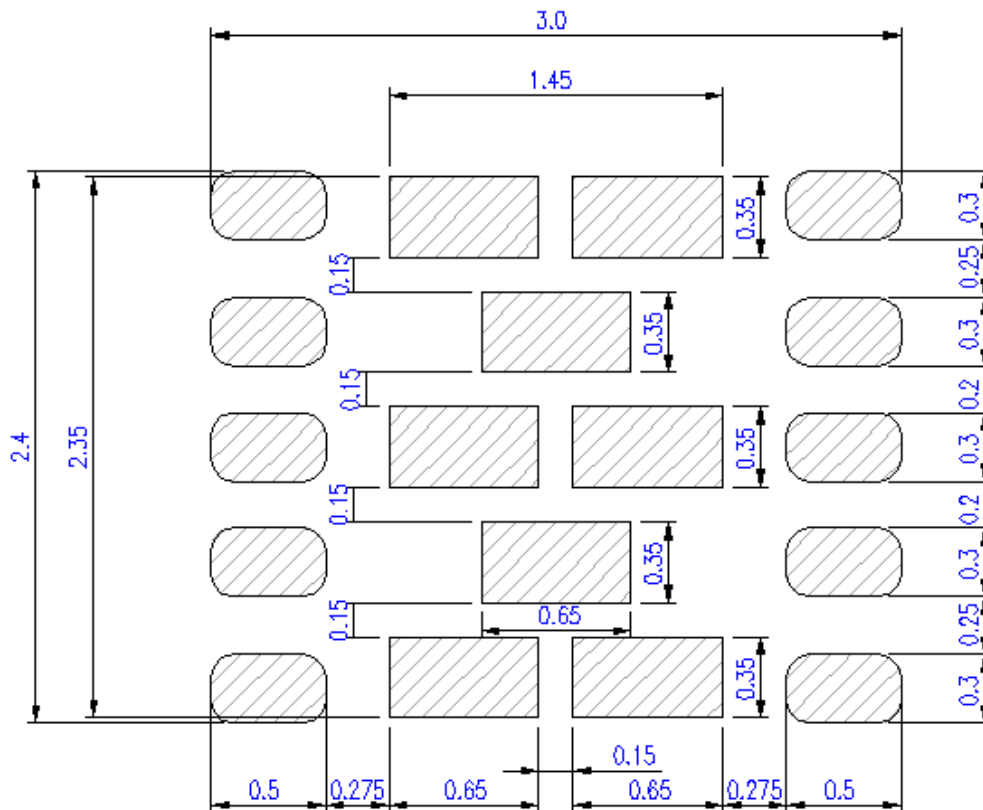

# N. PACKING SPECIFICATION:

UNIT : mm

## 【TAPING DIMENSION】

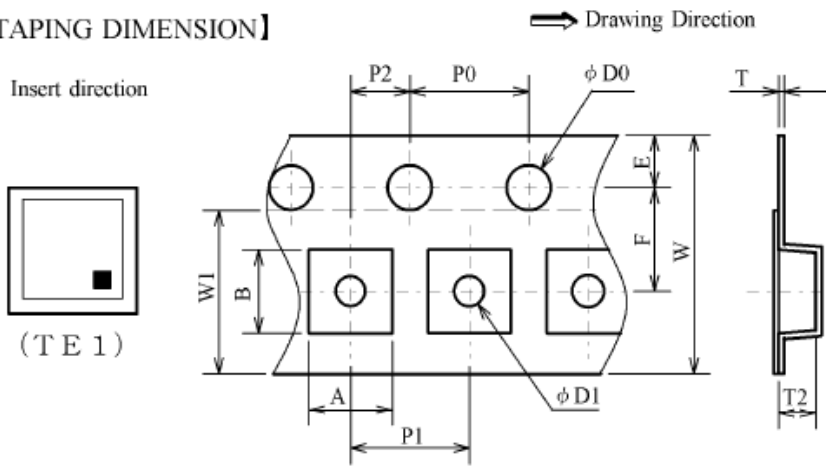

SYMBOL	DIMENSION	REMARKS
A	2.8±0.1	BOTTOM DIMENSION
B	2.8±0.1	BOTTOM DIMENSION
D0	1.5 <sup>+0.1</sup> <sub>-0</sub>	
D1	1.0 <sup>+0.1</sup> <sub>-0</sub>	
E	1.75±0.1	
F	3.5±0.05	
P0	4.0±0.1	
P1	4.0±0.1	
P2	2.0±0.1	
T	0.3±0.1	
T2	0.85±0.1	
W	8.0±0.2	
W1	5.3±0.2	THICKNESS100µmMAX

\*Carrier tape material: PS (Anti-static)  
Cover tape material: PET (Anti-static)

## 【REEL DIMENSION】

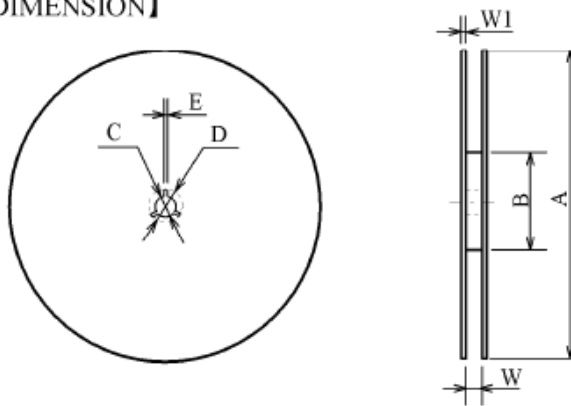

SYMBOL	DIMENSION
A	φ 180 <sup>+0</sup> <sub>-1.5</sub>
B	φ 66±0.5
C	φ 13±0.2
D	φ 21±0.8
E	2±0.5
W	9 <sup>+1.0</sup> <sub>-0</sub>
W1	1.2

\*MATERIAL : PS carbon (Anti-static)

## 【TAPING STATE】

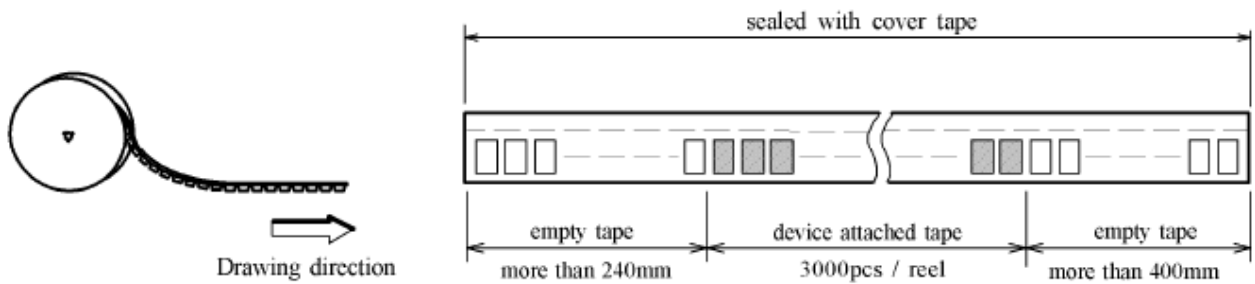

## O. RECOMMENDED REFLOW PROFILE:

\* Recommended reflow soldering procedure

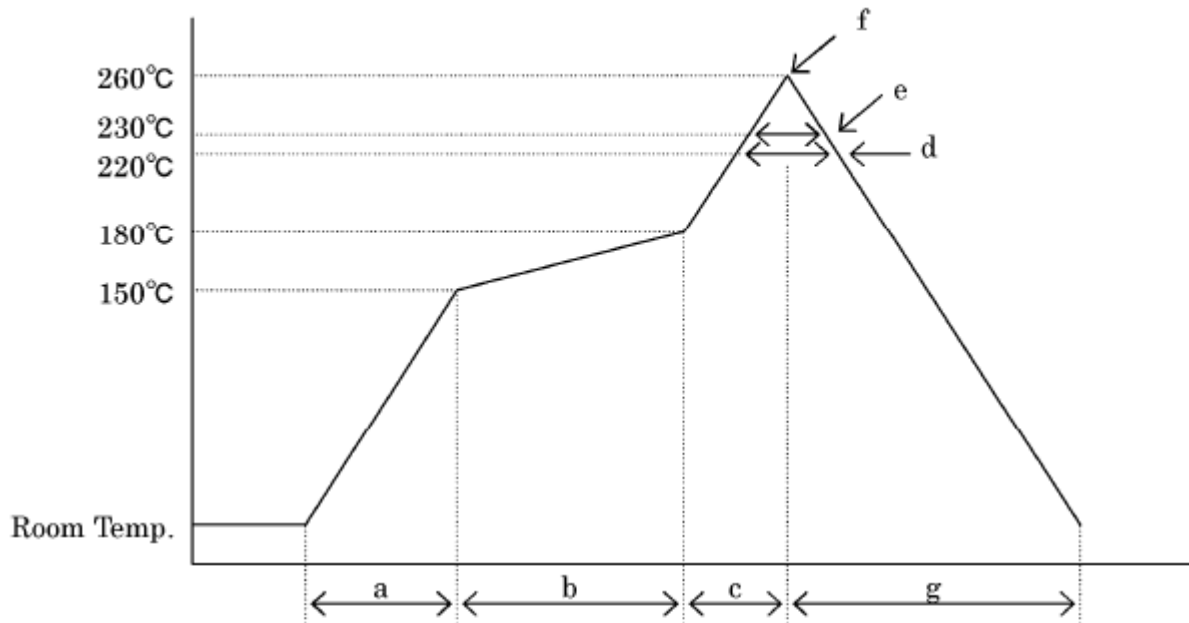

a: Temperature ramping rate	: 1 to 4°C/s
b: Pre-heating temperature	: 150 to 180°C
time	: 60 to 120s
c: Temperature ramp rate	: 1 to 4°C/s
d: 220°C or higher time	: Shorter than 60s
e: 230°C or higher time	: Shorter than 40s
f: Peak temperature	: Lower than 260°C
g: Temperature ramping rate	: 1 to 6°C/s

The temperature indicates at the surface of mold package.

### Cautions on using this product

This product contains Gallium-Arsenide (GaAs) which is a harmful material.

- Do NOT eat or put into mouth.
- Do NOT dispose in fire or break up this product.
- Do NOT chemically make gas or powder with this product.
- To waste this product, please obey the relating law of your country.

This product may be damaged with electric static discharge (ESD) or spike voltage. Please handle with care to avoid these damages.